

Intellian



OW11FL

Enterprise Flat Panel for Land



- ENTERPRISE
- GOVERNMENT
- COMMUNITY BROADBAND
- CELLULAR BACKHAUL

The OW11FL is Intellian's leading Flat Panel Enterprise user terminal, designed to deliver high reliability and performance to enterprise customers.

Designed with increased G/T and EIRP over scan, the OW11FL is the only Flat Panel UT that can ensure SLA and CIR commitments are achieved, making it the ideal solution for enterprise, community broadband, and government applications.

Intellian's Flat Panel Series consists of a portfolio of Enterprise and Compact user terminals, based on active electronically scanned arrays (AESAs) for Fixed Enterprise, Maritime and Land Mobility customers.

Optimized Performance



Utilizing Intellian's innovative antenna design, the OW11FL delivers the maximum throughput allowed on the OneWeb network. Offering the highest link margin, performance is guaranteed even over scan and at the lowest elevation angles, ensuring we meet the highest demands of enterprise customers.

Customer Network Exchange



Intellian's Customer Network Exchange (CNX) units are a critical component of any OneWeb user terminal installation, providing both the power and data connectivity to the Flat Panel user terminal, and the connectivity to customer equipment and networks. CNX variants are offered for specific deployment scenarios including Land Fixed, Maritime and Land Mobility.

Seamless Connectivity



The OW11FL features Intellian's advanced tracking technology, facilitating continuous, reliable handovers even at the lowest elevation angles encountered in equatorial regions. Delivering the best performance at scan, the innovative flat panel technology facilitates seamless and uninterrupted connectivity.

Extreme Temperature Performance



The OW11FL is designed to ensure dependable performance in even the most demanding environments, operating in extremely low temperatures down to -40 °C and up to +55 °C (-40 °F to 131 °F), delivering reliable broadband services for customers situated in the most remote locations.

Simplified Installation



The lightweight design and sleek form factor enables easy installation by a single person. Designed for use with standard off-the-shelf mounting solutions, the OW11FL can be deployed in a variety of locations to suit the application and environment. Installation is further simplified through use of combined power and data over a single coax cable connecting the indoor and outdoor units. The use of Intellian's mobile app for site survey, automated configuration, and monitoring further reduces the time required to get online.



OW11FL Technical Specifications

Outdoor Unit

Throughput (peak)	DL: 195 Mbps / UL: 37 Mbps
G/T	10.7 dB/K
EIRP	+36.6 dBW (Dual Carrier)
Field of View	+/- 70° from Zenith, 360° Azimuth
Size	96 cm x 50 cm x 12 cm (37.8" x 19.7" x 4.7")
Weight	16 kg (35 lb)
Power	340 W (max) 300 W (avg)
Ingress	IP66
Operating Temp	-40 °C to +55 °C (-40 °F to 131 °F)
Interface	F-Type conn

System Diagram

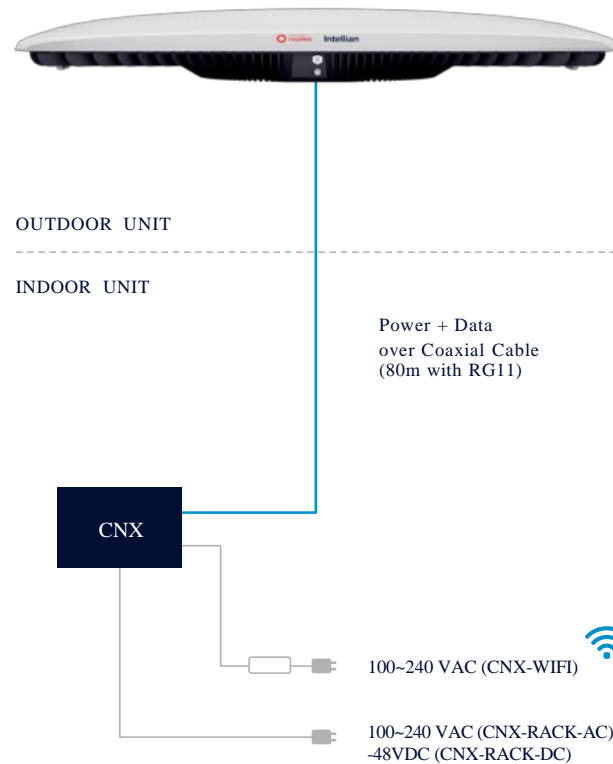

Indoor Units

	CNX-WIFI	CNX-RACK
Dimensions	21 cm x 17 cm x 8 cm (8.2" x 6.7" x 3.1")	44.2 cm x 25 cm x 4.4 cm (19" x 1 RU chassis)
Weight	0.6 kg (1.3 lb)	6.3 kg (13.9 lb)
Power	18 W (max), 8 W (avg)	30 W (max), 16 W (avg)
Operating Temp	0 °C to +40 °C (32 °F to 104 °F)	-15 °C to +55 °C (5 °F to 131 °F)
Data Interface	WiFi-6 4-port GigE RJ45	8-port GigE RJ45, 1x USB (Type-A) 1x NMEA0183
Power Input	Universal AC Power (100 – 240VAC)	Single or Dual 450W Power Modules 100 – 240 VAC (CNX-RACK-AC) or -48VDC (CNX-RACK-DC)



Installation

Standard 60mm end-cap included with flat panel for fixed land installation. Embedded hardware sensors and software compensates for true north and tilt error.



Insat.ca / 1.855.566.3932 (1.855.5 ONEWEB)